

**LINSEIS**

T H E R M A L   A N A L Y S I S

# TEG-Tester

Characterization of  
Thermoelectric Generators  
and Peltier-Elements

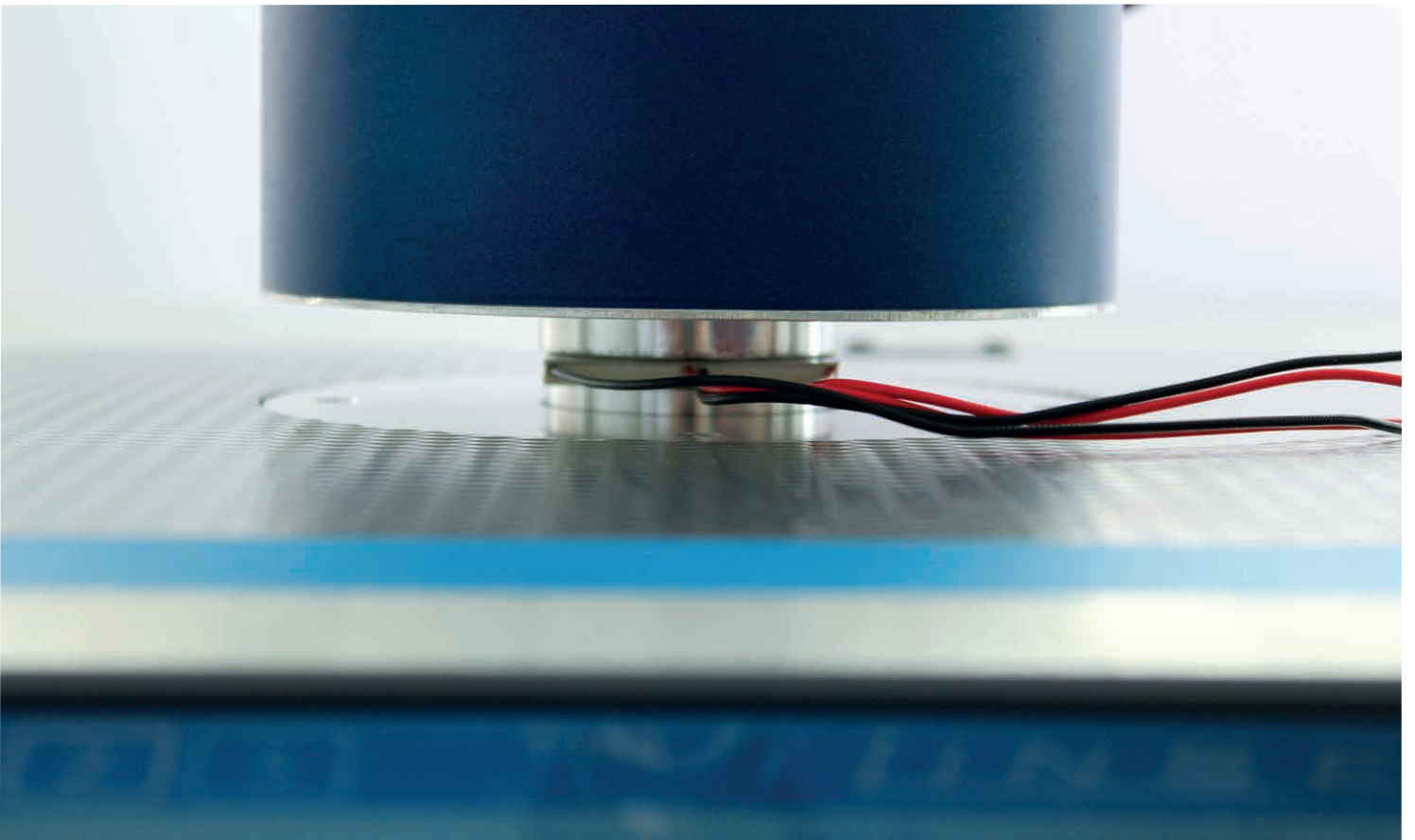

---

Since 1957 LINSEIS Corporation has been delivering outstanding service, know how and leading innovative products in the field of thermal analysis and thermo physical properties.

Customer satisfaction, innovation, flexibility and high quality are what LINSEIS represents. Thanks to these fundamentals our company enjoys an exceptional reputation among the leading scientific and industrial organizations. LINSEIS has been offering highly innovative benchmark products for many years.

The LINSEIS business unit of thermal analysis is involved in the complete range of thermo analytical equipment for R&D as well as quality control. We support applications in sectors such as polymers, chemical industry, inorganic building materials and environmental analytics. In addition, thermo physical properties of solids, liquids and melts can be analyzed.

LINSEIS provides technological leadership. We develop and manufacture thermo analytic and thermo physical testing equipment to the highest standards and precision. Due to our innovative drive and precision, we are a leading manufacturer of thermal Analysis equipment.

The development of thermo analytical testing machines requires significant research and a high degree of precision. LINSEIS invests in this research to the benefit of our customers.



Claus Linseis  
Managing Director

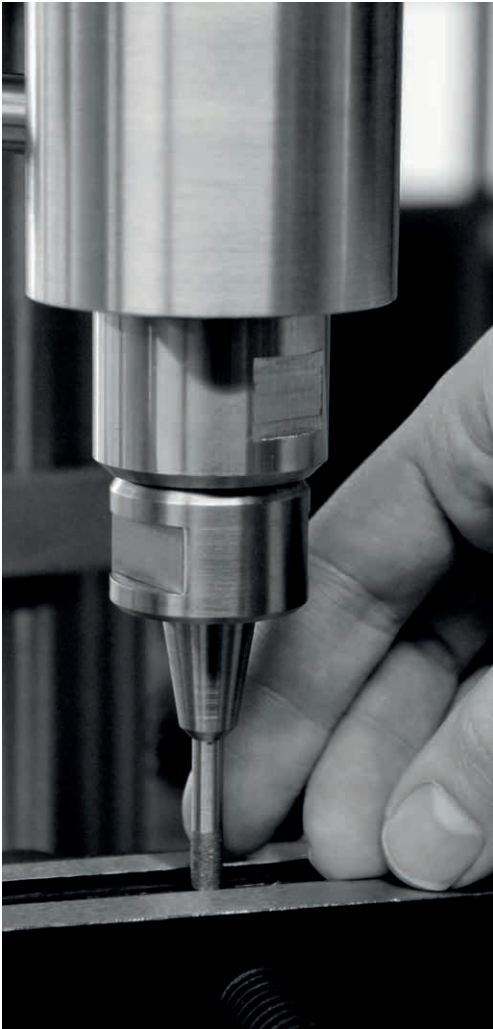

## German engineering

The strive for the best due diligence and accountability is part of our DNA. Our history is affected by German engineering and strict quality control.

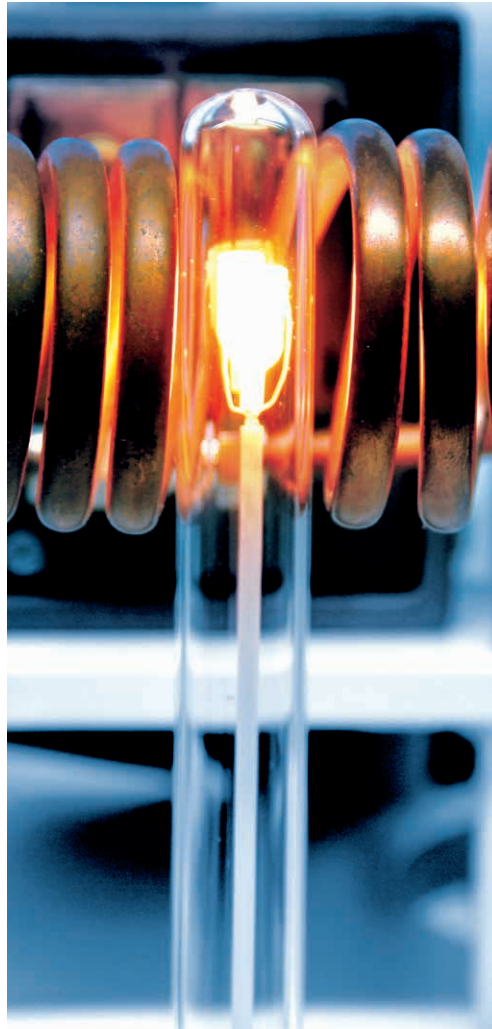

## Innovation

We want to deliver the latest and best technology for our customers. LINSEIS continues to innovate and enhance our existing thermal analyzers. Our goal is constantly develop new technologies to enable continued discovery in Science.

---

# GENERAL



Automatic pressure adjustment using electric actuator (up to 8 MPa)

Automatic thickness determination using high resolution LVDT

Instruments working according to ASTM D5470

Full integrated, software controlled device (MPP-tracking with variable load)

In recent years there is an increasing demand of renewable energy technologies as well as the optimization of the alternative fossil resources to the upper limit. The thermoelectricity provides the opportunity to convert thermal energy directly into electricity and represents one way to harness yet unused waste heat from industrial processes, exhaust systems of vehicles or even from body heat.

Discovered by the German physicist Thomas Johann Seebeck in 1821, the Seebeck-Effect is the basis for thermoelectric power generation. Beside the Seebeck-Effect, the Peltier-Effect and the Thomson-Effect appear at the same time and are summarized with the term thermoelectric phenomena. The devices that enable the thermoelectric power generation are called thermoelectric generators (TEGs) and their performance can be characterized in different ways. Altenkirch (1909) showed that good thermoelectric materials should possess a high Seebeck coefficient, high electrical conductivity and low thermal conductivity which leads to the introduction of the so called figure of Merit, ZT. ZT is a dimensionless value and defined as:

$$ZT = \frac{\alpha^2 \cdot \sigma}{\lambda} \cdot T$$

ZT: Figure of Merit  
 $\alpha$ : Seebeck Coefficient [ $\mu\text{V/K}$ ]  
 $\sigma$ : Electrical Conductivity [ $1/\Omega\text{m}$ ]  
 $\lambda$ : Thermal Conductivity [ $\text{W/mK}$ ]  
 $T$ : Temperature of the hot side [ $\text{K}$ ]

Thus the conversion efficiency can be calculated as:

$$\eta = \frac{T_H - T_C}{T_H} \cdot \frac{\sqrt{1 + Z\bar{T}} - 1}{\sqrt{1 + Z\bar{T}} + \frac{T_C}{T_H}}$$

$\eta$ : Conversion efficiency  
 $T_H/T_C$ : Temperatur of the hot/cold side [ $\text{K}$ ]  
 $Z\bar{T}$ : Average figure of Merit of the TEG

Nevertheless the real conversion efficiency of a thermoelectric module depends on many more parameters such as thermal contact resistances, ambient temperatures or load resistance. For the characterization of thermoelectric generators under real world conditions, the ratio of applied thermal load to electrical output power under defined load conditions is used:

$$\eta = \frac{P_{el}}{\dot{Q}_{TEG}}$$

$P_{el}$ : generated electrical power output [ $\text{W}$ ]  
 $\dot{Q}_{TEG}$ : thermal power input [ $\text{W}$ ]

---

# DESCRIPTION

The TEG-Tester (TEG L34) is a measurement system for temperature dependent conversion efficiency evaluations for thermoelectric generators (TEGs). The module is positioned between a hot and a cold meter bar, where the hot meter bar is connected to a regulated heating stage and the cold meter bar is connected to a thermostatically controlled, liquid cooled heat sink. The contact pressure on the sample can be automatically adjusted with an integrated electric actuator (in terms of pressure stability over temperature).

Due to the temperature setting point, a gradient is applied across the thermoelectric device and the heat flow through the reference block meter bars and into the TEG is measured. The generated voltage and current is scanned at different points to get the I-V curves or operate the TEG under a dynamic load. Hence it is possible to calculate the efficiency and tracking the maximum power point via perturb and observe method.

## FEATURES

TEG testing under „real world“ operational conditions:

- With a dynamic Load (e.g constant current)
- I-V Curve scanning / IC Tracing
- Automatic mechanical load with pressure compensation
- Different modes of operation (CC, FOC, MPPT, P&O)

## EVALUATION

Evaluation of:

- Heat flow
- Average Seebeck coefficient
- Average thermal conductivity
- Average module resistance
- Power output
- Module conversion efficiency



Different meter bars

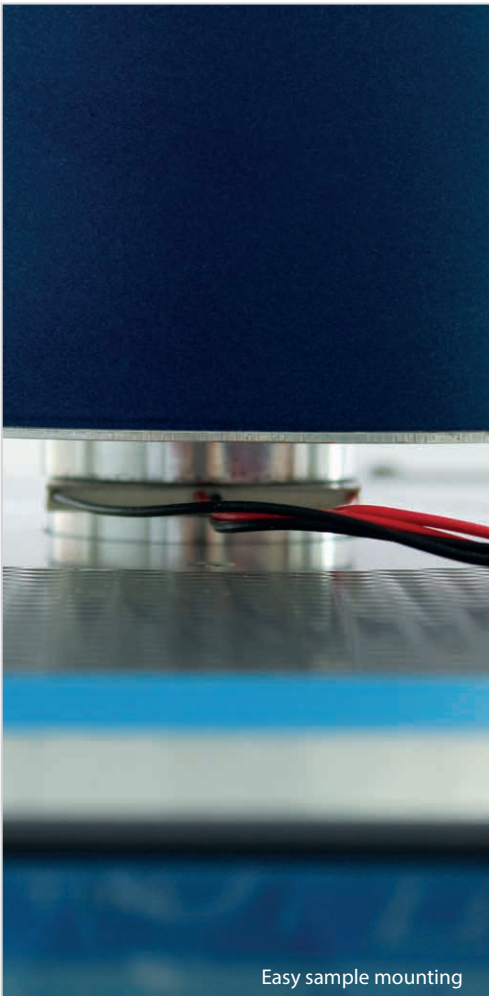

Easy sample mounting

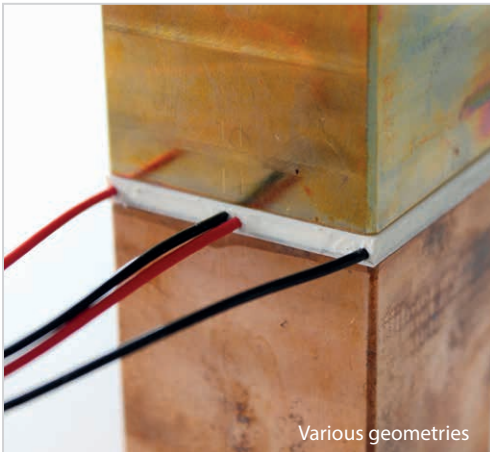
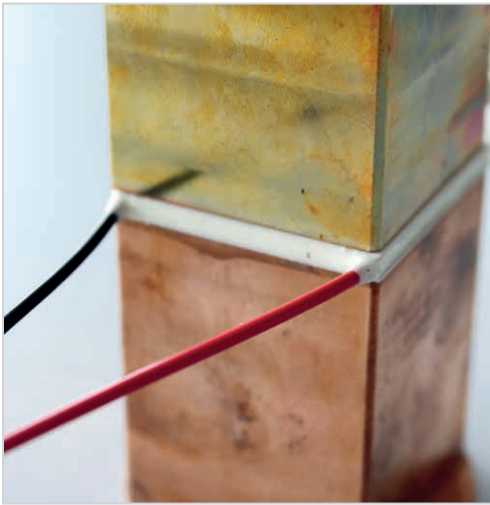

Various geometries

# CROSS SECTION

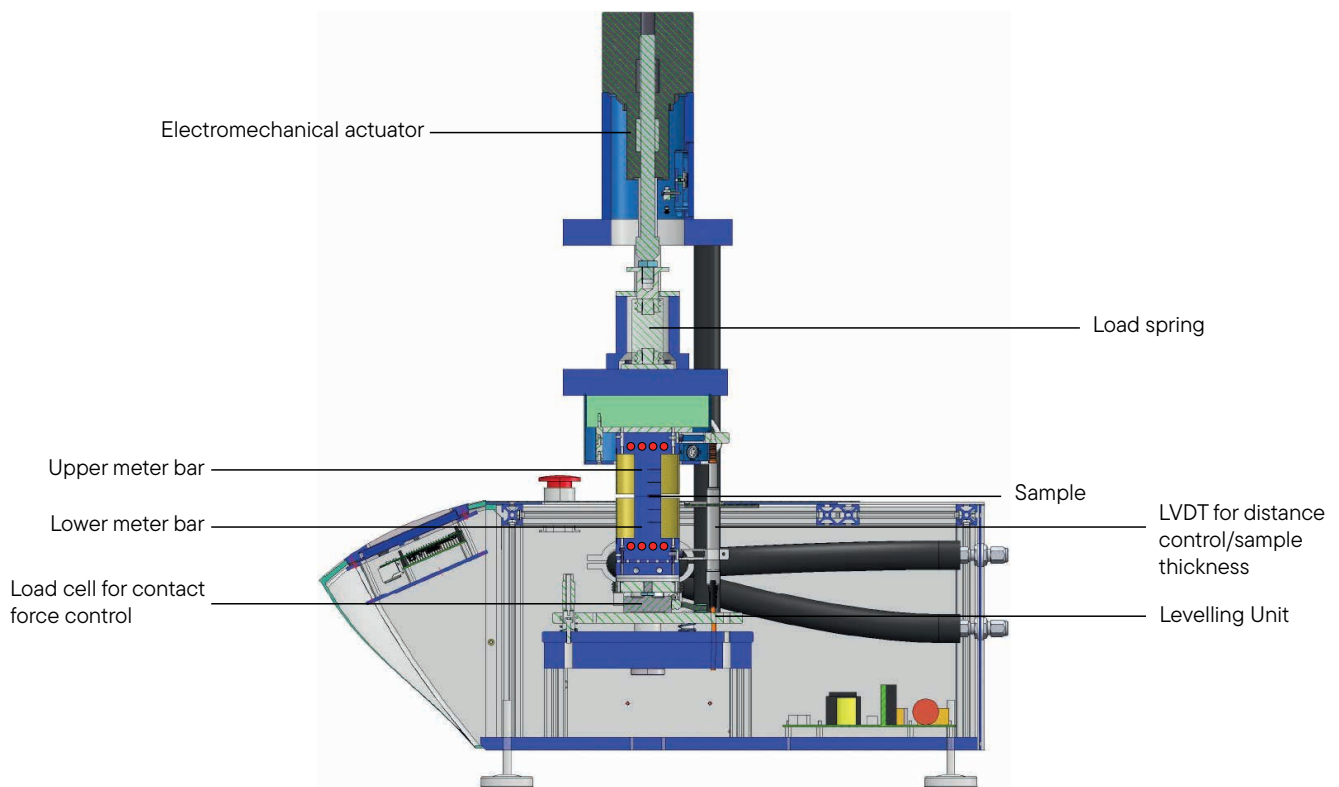





# SPECIFICATIONS

	TEG-Tester
<b>Specifications</b>	
Max. area	Round:     ∅ 20 mm, 25 mm, 40 mm, 60 mm Rectangular: 20 mm x 20 mm, 25 mm x 25 mm, 40 mm x 40 mm Other sizes on request
Max. height	up to 25 mm
Thickness accuracy	± 0.1% at 50% stroke / ± 0.25% at 100% stroke
Temperature	RT up to 300°C (hot side) / –20 up to 300°C
Temperature accuracy	0.1°C
<b>Measurement ranges</b>	
Voltage	0 – 12 V (DC)
Accuracy	0.3 %
Resolution	1.6 µV
Current	0 – 31 A (DC)
Accuracy	0.3 %
Resolution	1 µA
Power Dissipation	up to 36 W
Reference block material	Aluminium, brass, copper (others on request)
Temperature sensors	Thermocouple Type E
Clamping force	2 kN up to 5 kN (electric actuator)
Heating power	1.0 kW
<b>Intracooler (recommended)</b>	
Cooling capacity	1.0 kW (10°C) / 0.5 kW (-20°C)
Pump capacity	27 l/min / 0.7 bar
Tank capacity	3.8 l up to 7.5 l
Refrigerant used	R449 fluid

# APPLICATIONS

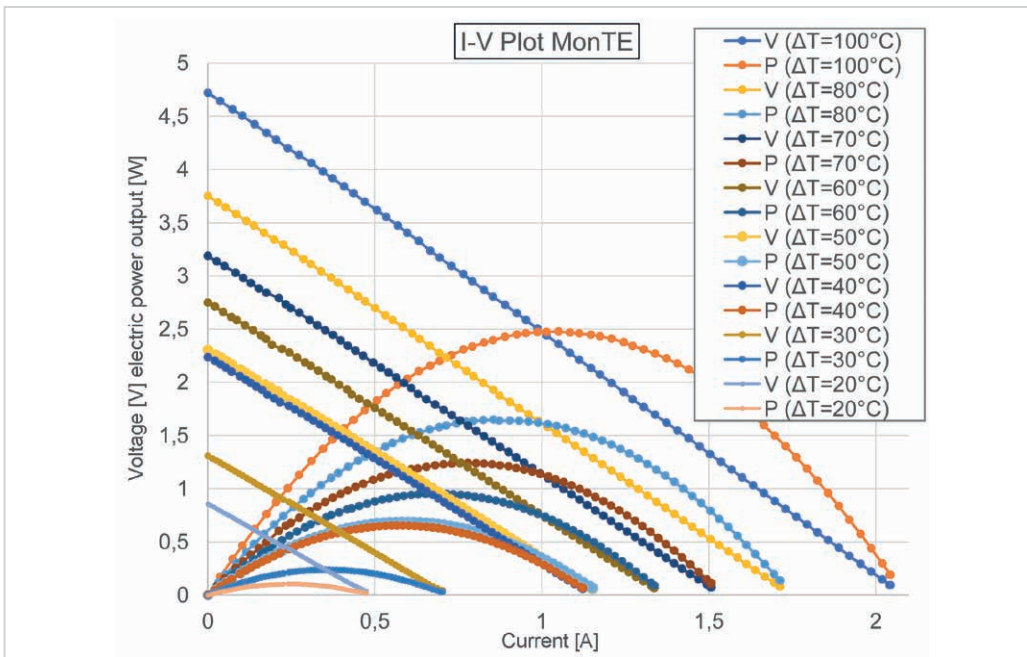

Electrical characterization plots (V-I and P-I curves from open circuit  $V_{OC}$  to short circuit  $I_{SC}$ ) of a standard  $\text{Bi}_2\text{Te}_3$  thermoelectric module (monTE) for different temperature gradients from  $\Delta T = 20\text{K}$  to  $100\text{K}$ .

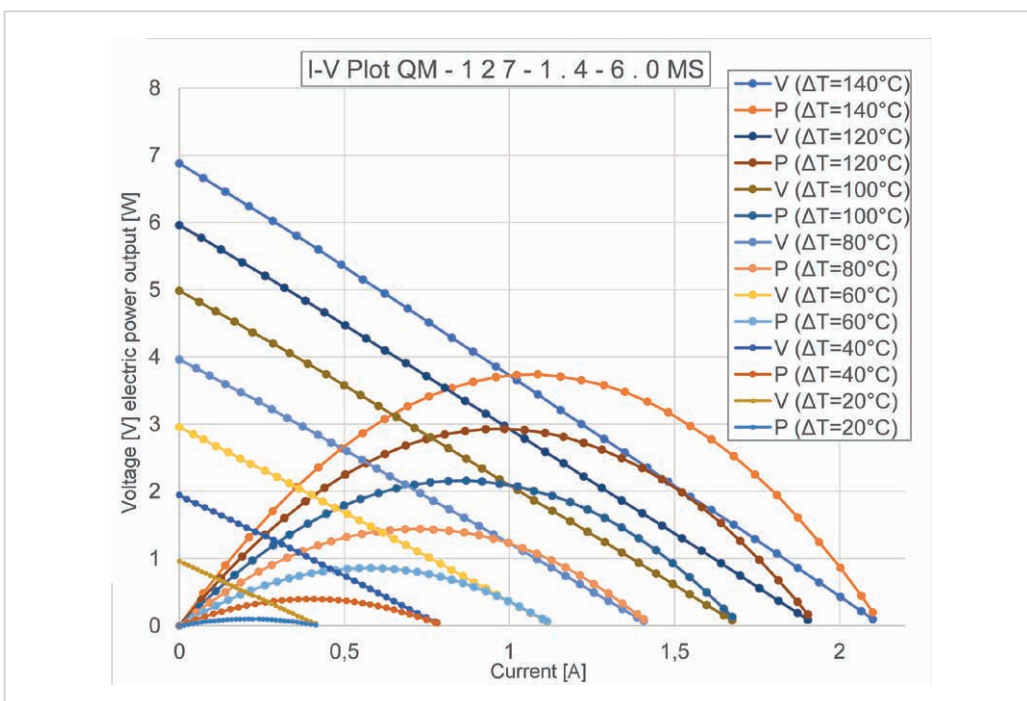

Electrical characterization plots (V-I and P-I curves from open circuit  $V_{OC}$  to short circuit  $I_{SC}$ ) of a standard  $\text{Bi}_2\text{Te}_3$  thermoelectric module (QM-127-1.4-6.0MS) for different temperature gradients from  $\Delta T = 20\text{K}$  to  $140\text{K}$ .



LINSEIS GmbH Germany

Vielitzerstr. 43

95100 Selb

Tel.: (+49) 9287 880 0

E-mail: [info@linseis.de](mailto:info@linseis.de)



LINSEIS Inc. USA

109 North Gold Drive

Robbinsville, NJ 08691

Tel.: (+1) 609 223 2070

E-mail: [info@linseis.com](mailto:info@linseis.com)



LINSEIS China

Kaige Scientific Park 2653 Hunan Road

201315 Shanghai

Tel.: (+86) 21 5055 0642

Tel.: (+86) 10 6223 7812

E-mail: [info@linseis.com](mailto:info@linseis.com)



Linseis Thermal Analysis India Pvt. Ltd.

Plot 65, 2nd floor, Sai Enclave, Sector 23

Dwarka

110077 New Delhi

Tel.: +91 11 42883851

E-mail: [sales@linseis.in](mailto:sales@linseis.in)

[www.linseis.com](http://www.linseis.com)

Products: DIL, TG, STA, DSC, HDSC, DTA, TMA, MS/FTIR, In-Situ EGA, Laser Flash, Seebeck Effect, Thin Film Analyzer, Hall-Effect

Services: Service Lab, Calibration Service

03/25

**LINSEIS**